

**ASKO**  
Inspired by Scandinavia



# Tumble Dryer

Style

*Note: Hidden Helper™ is featured above, placed in between the Tumble Dryer and Washing Machine.*



### More steel less plastic

Manufactured with high-quality stainless steel that can withstand the test of time. Designed to last for 20 years.



### Butterfly Drying™

Prevents laundry from getting tangled up in a ball.



### Sensi Dry™

Measures moisture in and around the machine, which prevents unnecessary over drying and shrinkage.

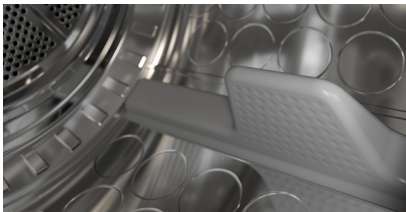

### Soft Drum™ and Air Lift™ paddles

Improves air circulation around laundry, increases the effectiveness of drying, and is more gentle.



### XL loading capacity

24.3 lb loading capacity and 2.8 cu ft drum volume. Can fit queen and king-size comforters.

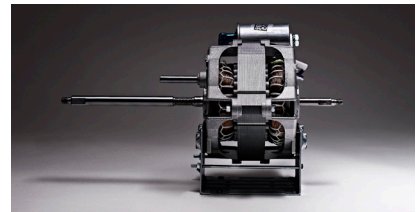

### Long-life brushless motor

Increases the lifespan of the dryer, reduces energy consumption and noise.



### T611VUW

Front-loaded tumble dryer  
 White // Loading capacity: 24.3 lb  
 Vented

## Tumble dryer — Style

**Drying without bundling: Butterfly Drying™, Low noise and long life-time: Brushless motor, Drum illumination for easier loading and unloading: Load Light™, Easy installation**



### Features

- Hygienic and durable stainless steel drum
- Galvanized sturdy steel casing
- 5 ball bearings to ensure smooth operation and longevity // Durable and silent brushless motor
- 20 years of domestic use (Tested for 10,000 hours, 160 cycles per year)

### Performance

- Butterfly Drying™ for optimal distribution of the load and prevention against bundling
- Quick Pro program - effective drying in just 59 minutes
- Extra careful drying for silk and wool
- Perfect dryness level with auto programs and temperature sensor

### Comfort

- Easy to read LCD display // Display of remaining time
- Line concept with program memory function
- 24 hour delayed start // Signal at the end of the program
- 2 US Gal water tank // Full water tank indicator // Connection to drain possible
- Adjustable feet // Possible to stack on an ASKO washing machine
- ASKO Washer can be connected to ASKO dryer - valid for all ASKO washers and all ASKO dryers
- Door is reversible
- Load Light™ - drum illumination for easier loading and unloading

### Programs

- 14 programs: Auto jeans, Auto normal dry, Auto down, Auto synthetics, Auto dry, Auto iron dry, Auto extra dry, Time program, Airing, Bedding, Shirts, SportWash, Quick Pro, Conditioning, Auto terry

### Options

- Dryness level, Gentle dry, Load size, Delayed start, Anti-crease, Steam finish, Adding to favorite program

### Settings

- Child lock, Set language, Sound settings, Display settings, Customize programs, Condensed water, Reset

### Safety

- Overheating protection // Overfill prevention // Child safe door

### Dimensions

- Appliance dimensions (H x W x D): 33 7/16" x 23 7/16" x 30 1/4" (850 x 595 x 769 mm)
- Length of the power cable: 66 15/16" (1700 mm)

### Technical data

- Loading capacity:
- Number of programs:
- Drum volume:
- Noise level (dB(A) re 1 pW):
- Estimated annual energy consumption:
- Electrical requirements:
- Electrical connection:

### Vented

- 24,3 lb
- 14
- 5.1 cu ft
- 65 dB(A)
- 630 kWh
- 208-240V / 15A / 60Hz
- Unit comes ready fitted with a 208-240V 30A plug

### Installation\*

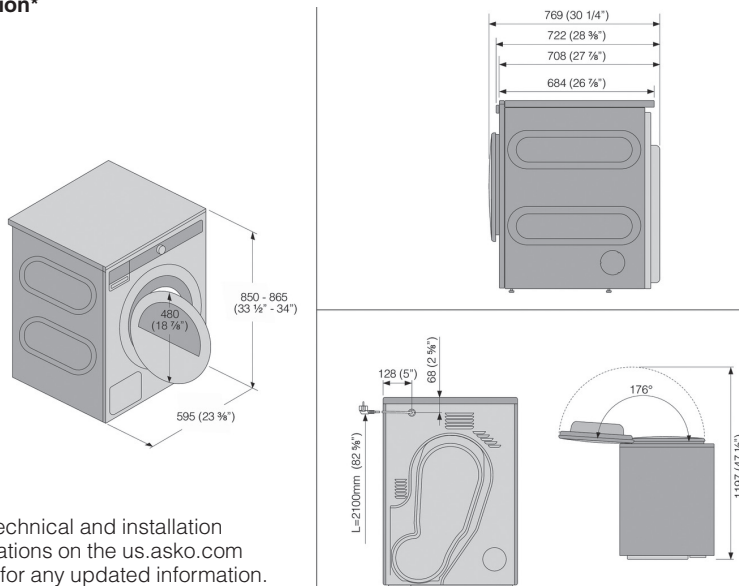

\*Check technical and installation specifications on the [us.asko.com](http://us.asko.com) website for any updated information.